

## Style 711 Bolted Couplings

For Seal & Restraining Joints on any combination of Steel and P. E. Pipe

The Dresser Style 711 coupling offers the convenience of an assembled stab product, essentially eliminating the component disassembly while helping to ensure proper installation.

The combination of components on the compression end(s) of the Style 711 product design results in a “pressure seal” while the metallic gripping mechanism locks the pipe against pull-out providing a complete seal and restraining connection.

Insert stiffeners for P. E. pipe in all SDR sizes commonly used in gas piping systems can be furnished by Dresser. Pipe inserts are color-coded to assist with the identification of proper SDR.

The Style 711 coupling is supplied with AL-CLAD™ epoxy coating as standard. Applied under rigidly controlled factory conditions, this coating offers a quality and integrity unlikely to be matched in any field-applied coating.

Dresser Style 711 coupling exceeds the requirements of D.O.T. Code 192.283(b), provided the proper Dresser reinforcing insert stiffener is used in the P. E. pipe end.

### Style 711 Conductive Coupling

Style 711 conductive couplings feature armored pinned gaskets for cathodic protection, while 4140 carbon steel slotted grip rings provide pipe restraint. Middle ring and followers are constructed of mild carbon steel or ductile iron. All Style 711 products are provided with AL-CLAD fusion-bonded epoxy coating as standard.

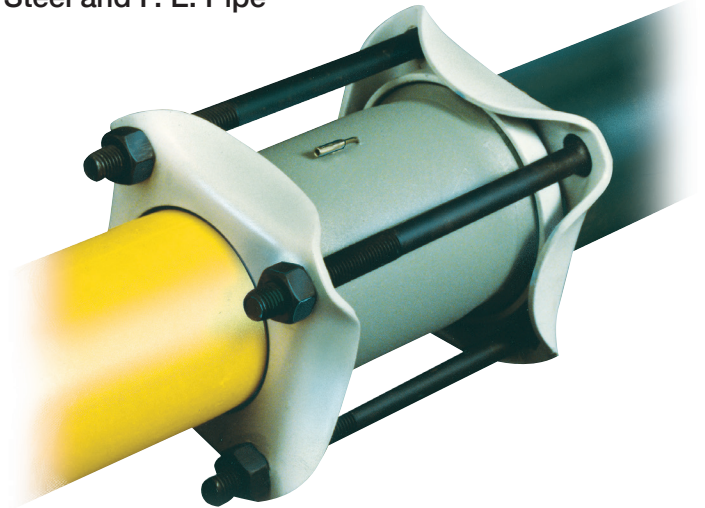
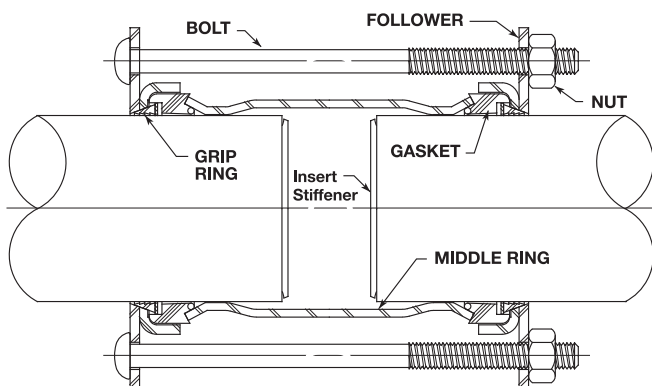

### For Steel and PE Connections

- Straight couplings, insulating and conductive
- Reducing couplings\*, insulating and conductive
- Flange Adapters
- Line Caps

\* Also available for CIP X Steel and CIP X PE Connections

### Style 711 Insulating Coupling

Style 711 insulating couplings offer the same seal and restraining principle, but feature insulating characteristics. PPO thermoplastic follower insulators, PP body insulators and HDPE/PVC pipe end spacers provide electrical isolation when joining pipes of dissimilar metals.

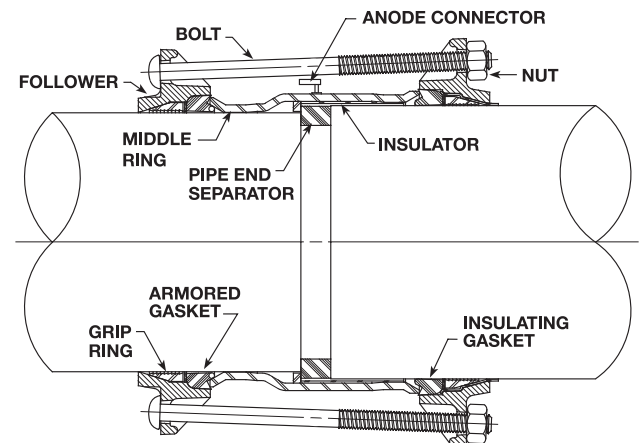

## Style 711 Bolted Couplings for P. E. to P. E., P. E. to Steel, and Steel to Steel Connections

### Conductive Sizes 1-1/4" - 12"

Pipe Size Nominal	Diameter	Product Ratings		P.E. Pipe Pullout Resistance up to the Max. Wall Listed Meets or Exceeds D.O.T. 192.283 (b)		Weight per Coupling Less Insert
		Max. Sealing Pressure	Max. Steel Pipe Pullout Resistance	Type 2306/2406	Type 3406/3408	
1-1/4	1.660	150 psi	2,500 lbs	SDR 10	SDR 9.3	5
2	2.375	150 psi	6,300 lbs	SDR 9.3	SDR 9.3	8
3	3.500	300 psi	13,000 lbs	SDR 9.3	SDR 9.3	16
4	4.500	300 psi	14,000 lbs	SDR 9.3	SDR 9.3	25
6	6.625	300 psi	22,000 lbs	SDR 11	SDR 11	38
8	8.625	150 psi	37,300 lbs	SDR 11	SDR 11	54
10	10.750	150 psi	69,000 lbs	SDR 11	SDR 11	107
12	12.750	150 psi	50,800 lbs	SDR 13.5	N/A	93
12	12.750	150 psi	100,000 lbs	SDR 11	SDR 11	132

### Insulating Sizes 2" - 8"

Pipe Size Nominal	Diameter	Product Ratings		P.E. Pipe Pullout Resistance up to the Max. Wall Listed Meets or Exceeds D.O.T. 192.283 (b)		Weight per Coupling Less Insert
		Max. Sealing Pressure	Max. Steel Pipe Pullout Resistance	Type 2306/2406	Type 3406/3408	
2	2.375	150 psi	6,300 lbs	SDR 9.3	SDR 9.3	8
3	3.500	300 psi	13,000 lbs	SDR 9.3	SDR 9.3	16
4	4.500	300 psi	14,000 lbs	SDR 9.3	SDR 9.3	25
6	6.625	300 psi	22,000 lbs	SDR 11	SDR 11	38
8	8.625	150 psi	37,300 lbs	SDR 11	SDR 11	54
10**	10.750	150 psi	69,000 lbs	—	—	86
12**	12.750	150 psi	50,800 lbs	—	—	93

NOTE 1: For wall thickness greater than SDR listed, contact Dresser for recommendation.

Pull-out resistance is based on using Dresser reinforcing pipe inserts.

NOTE 2: For all sizes and configurations, please refer to your Dresser Price List or contact your Dresser sales representative.

### DRESSER NGS Insert Stiffeners

Pipe Size Nominal	SDR	Stiffener O.D. ± .015	Length
1-1/4	9.3	1.260	7
	10	1.297	
	11	1.312	
	13.5	1.400	
2	9.0	1.625	7
	9.3	1.834	
	11	1.900	
	13.5	2.000	
3	9.3	2.688	8
	11	2.812	
	11.5	2.844	
	13.5	2.950	
4	9.3	3.461	8
	11	3.610	
	11.5	3.630	
	13.5	3.800	
	15.5	3.933	
	17	4.500	

Pipe Size Nominal	SDR	Stiffener O.D. ± .015	Length
6	11	5.323	8
	11.5	5.342	
	13.5	5.530	
	17	5.765	
	21	5.942	
8	23	6.017	8
	11	6.915	
	11.5	7.000	
	13.5	7.233	
10	17	7.550	8
	21	7.694	
	11	8.600	
	13.5	9.011	
12	15.5	9.246	9
	11	10.211	
	13.5	10.693	
12	17	11.097	9-1/4

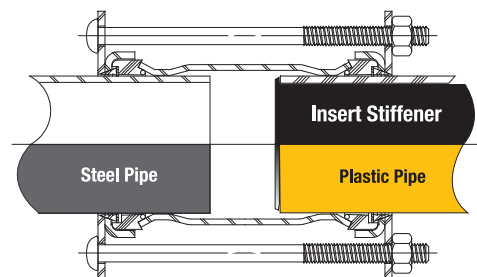

SDR Insert	Color Code
9	Yellow
9.3	Dark Blue
10	Grey
11	Black
11.5	Red
13.5	White
15.5	Brown
17	Purple
21	Green

## Style 711 Reducing Couplings for P. E. to P. E., P. E. to Steel, and Steel to Steel Connections

### Conductive Sizes 2" - 12"

Pipe Size Nominal	Diameter	Product Ratings		P.E. Pipe Pullout Resistance up to the Max. Wall Listed Meets or Exceeds D.O.T. 192.283 (b)		Weight per Coupling Less Insert
		Max. Sealing Pressure	Max. Steel Pipe Pullout Resistance	Type 2306/2406	Type 3406/3408	
2 x 1-1/4	2.375/1.660	150 psi	2,500 lbs	SDR 10	SDR 9.3	14
3 x 2	3.500/2.375	150 psi	6,300 lbs	SDR 9.3	SDR 9.3	18
4 x 2	4.500/2.375	150 psi	6,300 lbs	SDR 9.3	SDR 9.3	21
4 x 3	4.500/3.500	150 psi	13,000 lbs	SDR 9.3	SDR 9.3	21
6 x 4	6.625/4.500	150 psi	14,000 lbs	SDR 9.3	SDR 9.3	38
8 x 6	8.625/6.625	150 psi	22,000 lbs	SDR 11	SDR 11	45
10 x 6	10.750/6.625	150 psi	22,000 lbs	SDR 11	SDR 11	85
10 x 8	10.750/8.625	150 psi	37,300 lbs	SDR 11	SDR 11	141
12 x 10	12.750/10.75	150 psi	69,000 lbs	SDR 11	SDR 11	165

### Insulating Sizes 2" - 8"

Pipe Size Nominal	Diameter	Product Ratings		P.E. Pipe Pullout Resistance up to the Max. Wall Listed Meets or Exceeds D.O.T. 192.283 (b)		Weight per Coupling Less Insert
		Max. Sealing Pressure	Max. Steel Pipe Pullout Resistance	Type 2306/2406	Type 3406/3408	
2 x 1-1/4	2.375/1.660	150 psi	2,500 lbs	SDR 10	SDR 9.3	14
3 x 2	3.500/2.375	150 psi	6,300 lbs	SDR 9.3	SDR 9.3	17.5
4 x 2	4.500/2.375	150 psi	6,300 lbs	SDR 9.3	SDR 9.3	20.5
4 x 3	4.500/3.500	150 psi	13,000 lbs	SDR 9.3	SDR 9.3	20.5
6 x 4	6.625/4.500	150 psi	14,000 lbs	SDR 9.3	SDR 9.3	38
8 x 6	8.625/6.625	150 psi	22,000 lbs	SDR 11	SDR 11	45

NOTE 1: For wall thickness greater than SDR listed, contact Dresser for recommendation.

Pull-out resistance is based on using Dresser reinforcing pipe inserts.

### Style 711 Line Caps and Flange Adapters for Steel (IPS) and P. E. Pipe

Pipe Size Nominal	Diameter	Product Ratings		P.E. Pipe Pullout Resistance up to the Max. Wall Listed Meets or Exceeds D.O.T. 192.283 (b)		Weight per Fitting Less Insert	
		Max. Sealing Pressure	Max. Steel Pipe Pullout Resistance	Type 2306/2406	Type 3406/3408	Line Cap	Flange Adapter
1-1/4	1.660	150 psi	2,500 lbs	SDR 10	SDR 9.3	9	11
2	2.375	150 psi	6,300 lbs	SDR 9.3	SDR 9.3	13	15
3	3.500	150 psi	13,000 lbs	SDR 9.3	SDR 9.3	16	20
4	4.500	150 psi	14,000 lbs	SDR 9.3	SDR 9.3	20	26
6	6.625	150 psi	22,000 lbs	SDR 11	SDR 11	29	39
8	8.625	150 psi	37,300 lbs	SDR 11	SDR 11	38	53
10	10.750	150 psi	69,000 lbs	SDR 11	SDR 11	70	87
12	12.750	150 psi	50,800 lbs	SDR 13.5	N/A	87	100
12	12.750	150 psi	100,000 lbs	SDR 11	SDR 11	115	129

NOTE 1: For wall thickness greater than SDR listed, contact Dresser for recommendation.

Pull-out resistance is based on using Dresser reinforcing pipe inserts.

## Style 711 Reducing Couplings for Cast Iron Pipe

For Cast to P. E., and Cast to Steel

Pipe Size Nominal	Diameter	Product Ratings		P.E. Pipe Pullout Resistance up to the Max. Wall Listed Meets or Exceeds D.O.T. 192.283 (b)		Weight per Coupling with One Insert
		Max. Sealing Pressure	Max. Steel Pipe Pullout Resistance	Type 2306/2406	Type 3406/3408	
3 x 3	3.800/3.500	50 psi	13,000 lbs	SDR 9.3	SDR 9.3	28
3 x 3	3.960/3.500	50 psi	13,000 lbs	SDR 9.3	SDR 9.3	38
4 x 2	4.800/2.375	50 psi	6,300 lbs	SDR 9.3	SDR 9.3	29
4 x 3	4.500/3.500	50 psi	13,000 lbs	SDR 9.3	SDR 9.3	30
4 x 4	4.800/4.500	50 psi	14,000 lbs	SDR 9.3	SDR 9.3	32
4 x 6	5.000/4.500	50 psi	14,000 lbs	SDR 9.3	SDR 9.3	32
6 x 4	6.900/4.500	50 psi	14,000 lbs	SDR 9.3	SDR 9.3	45
6 x 6	6.900/6.625	50 psi	22,000 lbs	SDR 11	SDR 11	51
6 x 6	7.100/6.625	50 psi	22,000 lbs	SDR 11	SDR 11	51
8 x 6	9.050/6.625	50 psi	22,000 lbs	SDR 11	SDR 11	56
8 x 8	9.050/8.625	50 psi	37,300 lbs	SDR 11	SDR 11	60
8 x 8	9.300/8.625	50 psi	37,300 lbs	SDR 11	SDR 11	60
12 x 12	13.200/12.750	50 psi	100,000 lbs	SDR 11	SDR 11	140

NOTE 1: For wall thickness greater than SDR listed, contact Dresser for recommendation. Pull-out resistance is based on using Dresser reinforcing pipe inserts.

## Style 711 Insulated Line Cap for Cast Iron Pipe

Insulating Sizes 3" - 12"

Pipe Size Nominal	Diameter	Product Ratings		Weight per Coupling Less Insert
		Max. Sealing Pressure	Max. Steel Pipe Pullout Resistance	
3	3.800	50 psi	11,000 lbs	24
3	3.960	50 psi	11,000 lbs	24
4	4.800	50 psi	11,000 lbs	24
4	5.000	50 psi	11,000 lbs	24
6	6.900	50 psi	21,000 lbs	33
6	7.100	50 psi	21,000 lbs	33
8	9.050	50 psi	37,300 lbs	43
8	9.300	50 psi	37,300 lbs	43
12	13.200	50 psi	100,000 lbs	145

NOTE 1: For wall thickness greater than SDR listed, contact Dresser for recommendation. Pull-out resistance is based on using Dresser reinforcing pipe inserts.

NOTE 2: When used on Steel or CIP, the joint must be considered a rigid connection.

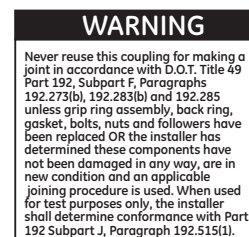
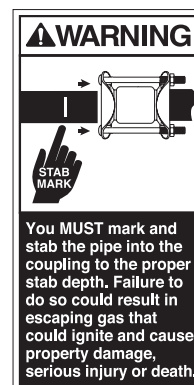
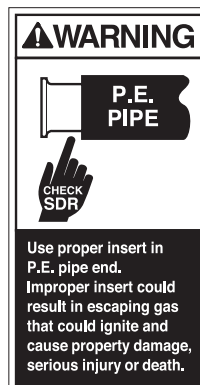

### Dresser™ Pipeline Solutions

41 Fisher Avenue  
Bradford, PA 16701  
T: 814.362.9200  
F: 814.362.9344



www.dresserngs.com

NGS-DPS-005  
711.DATA.SHEET.11.18