

DRESSER NGS

Gas Product Selection Guide

For Natural Gas Transmission & Distribution Piping Systems

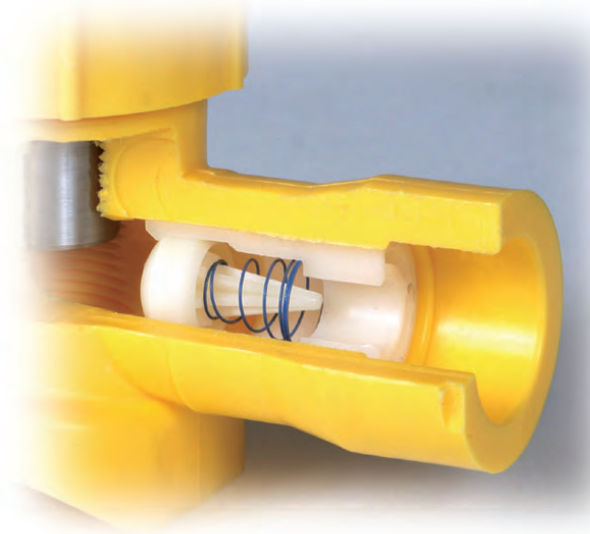

Specifying Dresser Gas Market Products

Since the first Dresser coupling patent was granted in 1886, many improvements in design, and advances in pipe joining technology have been achieved. This manual is recommended as a guide for specifying Dresser piping products on gas and oil distribution piping systems.

Dresser pipe joining products are categorized to accommodate two most common conditions: (1) to provide only a seal at the pipe joint, or (2) provide both sealing and restraint against pipe pullout. The Federal Department of Transportation's Code Part 192 addresses the issue of pipe end restraint of piping systems and has established performance requirements specifically related to seal only and restraining-type mechanical joints. (Ref. Paragraphs 192.273(a) and 192.283(b).) The pipeline engineer determines the required category of pipe joint based on the application for conformance to D.O.T. specs. Dresser product component drawing examples are shown on page 2 & 3 (seal & restraint) and page 4 (seal only) to illustrate these categories.

Since traditional mechanical couplings and fittings provide only a seal on the pipe end when installed, they may not provide lock or pipe restraint and, consequently, they do not prevent the pipe from pulling out of the coupling. Longitudinal pull-out or thrust forces caused by thermal expansion and contraction or by internal or external loads, whether anticipated (e.g., settlement of piping) or unanticipated (e.g., third party damage), must be considered when using mechanical type joints. This is especially true when installing polyethylene pipe, which is known to be affected by thermal expansion and contraction 10 to 15 times the rate of steel pipe.

Also, in situations where pipe movement might occur, it is necessary that the piping be properly anchored when using mechanical couplings and fittings. Failure to take this into consideration has been a major cause of pipe pull-out when non-restraining or non-locking mechanical joints were used.

Note: Applicable installation and usage warnings are shown on the back cover to help provide some guidelines for safe and reliable product installation.

A complete Gas Products DOT Installation Instruction Manual is available through your regional Dresser Sales Representative, or call 814-362-9200 and ask to speak with Gas Market Customer Service.

NOTE: DRESSER Natural Gas Solutions reserves the right to make changes in specifications and features shown herein, or discontinue the product described at any time without notice or obligation.



DRESSER Coupling & Fitting Components

The following is a general listing and function of Dresser gas product components:

- Anode Connector - An optional connection provided for attachments of an anode to the coupling, normally on the body or middle ring, for cathodic protection.
- Armor - A metallic gasket tip providing conductivity between the middle ring and follower as well as protection from attack by severe line content.
- Follower - Ring that retains the gasket and provides a means to compress the gasket and grip ring in bolted products.
- Follower Insulator - A high-dielectric annular sleeve formed to prevent conductivity between the pipe and coupling on the insulating pipe end.
- Gasket - Sealing component which is compressed upon installation, providing a pressure seal. Can be insulating or conductive.
- Bolt and Nut - Provides means of compressing the followers of a bolted coupling, providing a seal only or a seal & restraining joint, depending on coupling design.
- Compression Nut - The component that compresses the gasket and grip ring by tightening onto the body of threaded compression couplings and fittings.
- Grip Ring - Holds the pipe against pullout in couplings made for seal and restraint.
- Insert Stiffener - A tubular reinforcement sleeve used on all polyethylene pipe ends to prevent pipe collapse.
- Insulator - A high-dielectric cylindrical sleeve preventing electrical shorting between the pipe and middle ring.
- Middle Ring or Body - Pressure containing component that bridges the gap between pipe ends.
- Pipe End Separator - A high-dielectric plastic ring which prevents electrical shorting from pipe end to pipe end.
- Retainer Cup - Component that retains the gasket in a threaded compression fitting.

For specific product literature and specification details, please call Dresser Inside Sales at 814-362-9200 and request a PDF of the Gas Product Catalog. You can also visit us on the web for an overview of all gas products by Style Number. www.dresserngs.com

Seal & Restraint Couplings and Fittings

Current Product Line:

- Style 90 Universal Boltless Couplings & Fittings
- Style 90 Insulated Restraining Couplings
- Style 401 Couplings & Fittings
- Style 501 Compression Fittings
- Style 700 Universal POSI-HOLD™ Hydraulic Couplings
- Style 711 Couplings & Flange Adapters
- Style 711 Line Caps
- See Page 6 for Style 175 Valves (w/Universal 90 or 501 Compression Ends)

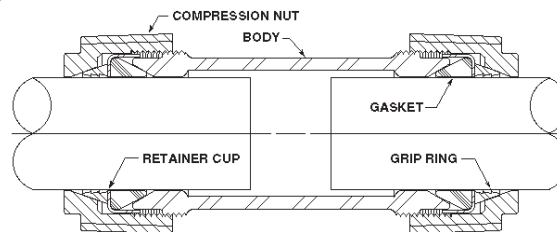



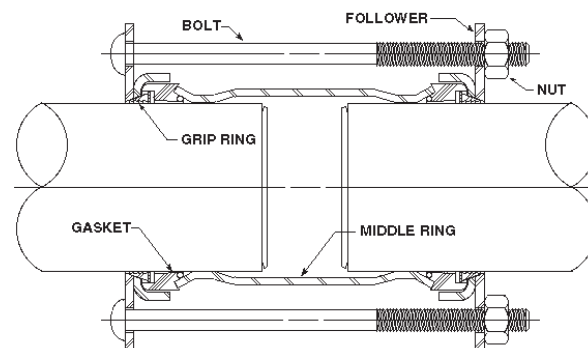



Style 90 Universal Coupling









Style 711 Coupling

Seal & Restraining Pipe Joining

These products create both a SEAL on the pipe and RESTRAINT against pipe pull-out.

PIPE	PRODUCT	STYLE NO.	CONFIGURATIONS	SIZES	PSI RATING
P.E. to P.E. P.E. to Copper		Style 401 SEAL-PLUS™ Couplings	Coupling, Ell, Tee, End Cap (Straight & Reducing)	5/8" - 1-3/8"	125 psig
P.E. to Steel		Style 501 x 90 Compression End Fitting	Coupling, Adapter, Reducing Coupling	3/4" - 2"	125 psig
Steel x P.E.		Style 88	Service Head Adapter for Steel x P.E. (Insert Included)	5/8" - 1-3/8" (CTS)	150 psig
P.E. to P.E. P.E. to Steel Steel to Steel		Style 90 Universal	Coupling, Ell Tee, Adapter (Straight & Reducing)	3/4" - 2"	150 psig
Steel x Steel Steel x P.E.		Style 90 Insulating	Insulating/Restraining Couplings	3/4" - 2"	150 psig
Steel x Steel Steel x P.E.		Style 90 Universal Service Tee	Tap-N-Valve Tee for IPS Services w/Compression Outlet	3/4" Weld x 3/4" 3/4" Weld x 1" 1" MIPS x 3/4"	150 psig

Pipe Joining Products Seal & Restraint (cont'd)

PIPE	PRODUCT	STYLE NO.	CONFIGURATIONS	SIZES	PSI RATING
Steel x Steel Steel x P.E.		Style 501 Service Tee	Tap-N-Valve Tee for Steel to CTS Polyethylene	5/8" & 1-1/8"	125 psig
Steel P.E.		Style 64 Bolted Riser Tee	Riser Tee with Insulating and Conductive End Configurations	3" & 4"	150 psig
Steel x P.E.		Style 502	Service Head Adapter FIPS, CTS x MIPS	3/4" - 1-1/2" 5/8" - 1-3/8" (CTS)	150 psig
P.E. to P.E. P.E. to Steel Steel to Steel		Style 700 POSI-HOLD® Hydraulic Couplings	Universal Boltless Coupling, Ell, Tee, Line Cap	3" - 8"	150 psig
P.E. to P.E. P.E. to Steel Steel to Steel		Style 711 Bolted Couplings	Coupling, Flange Adapter, Line Cap, Reducing Coupling (Conductive & Insulating)	1-1/4" - 12"	Varies by size and application
Cast to P.E. Cast to Steel			Insulating/Reducing Coupling	3.8" - 13.2"	50 psig
Steel/ P. E. Cast		Style 711 Bolted Line Cap	Restraining Line Cap with Vent	1-1/4" - 12"	150 psig
					3.8" - 13.23"

Seal & Restraining Insulating Products

Dresser insulating product designs are available to electrically isolate sections of piping for cathodically protected systems.

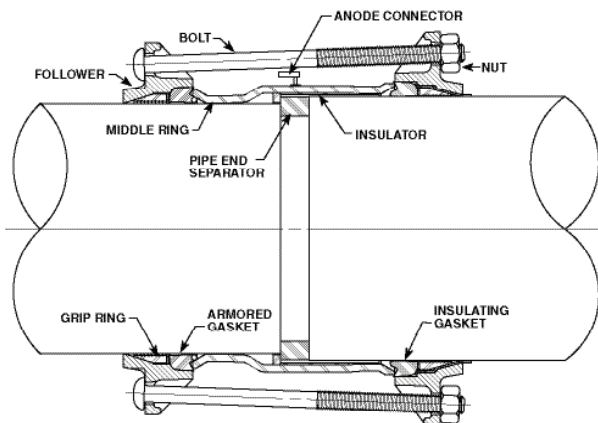

Style 711 Insulating/Reducing Coupling
Provides Seal AND Pipe Restraint

Other means of restraining pipe joints:

Restraining Joint Harnesses:

Used to bridge over a coupling to provide restraint to the joint.

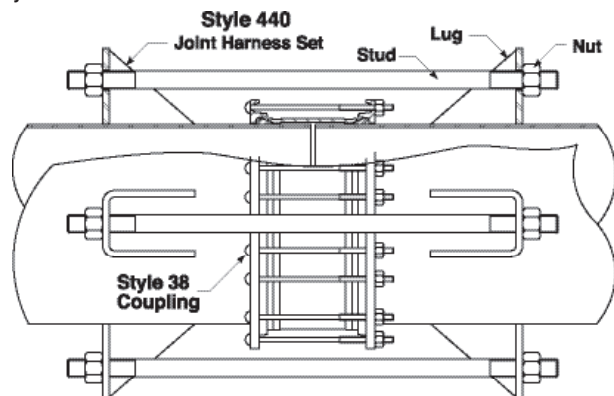

Style 440 Joint Harness
Used in conjunction with a Dresser Style 38
coupling on steel pipe installations

(See Product Details Page 10)

Seal-Only and Insulating Seal-Only Couplings and Fittings

Seal-Only Couplings & Fittings

Current Product Line::

- Style 38, 39, 40, 39-40 and 39-62 Couplings
- Style 63 Expansion Joints
- Style 60 and 160 Bell Joint Clamps
- Style 128 Flange Adapters
- Style 88 and 90 Compression Fittings
- Style 4, 41, 77, 118 and 360 Repair Clamps
- Style 50, 54, 73, 80, 96, and 126 Sleeves
- See Page 6 for Style 275 and 350 Meter Valves; and Style 351 Valve Strainers

Dresser insulating product designs are available to electrically isolate sections of piping for cathodically protected systems.

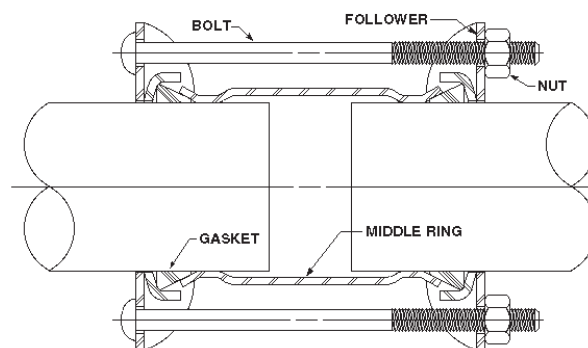



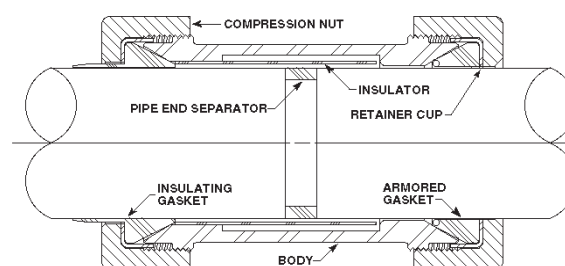

Style 38 Coupling
Provides Seal Only



Style 90 Insulating Coupling
Provides Seal Only and Insulating End

Seal-Only Pipe Joining Fittings









These products create a SEAL-ONLY on the pipe. They DO NOT provide restraint against pipe pull-out.

PIPE	PRODUCT	STYLE NO.	CONFIGURATIONS	SIZES	PSI RATING
Copper Tubing		Style 88 Compression Fittings	Brass Coupling, Male & Female Adapters	1/2" - 1-1/4" 5/8" - 1-3/8" (CTS)	150 psig
Steel x CTS		Style 88	Service Head Adapter for Steel x Copper Tubing (Insert Included)	1" - 2" 5/8" - 1-3/8" (CTS)	150 psig
Steel to Steel		Style 90 Compression Fittings	Coupling, Reducing Coupling, Ell, Tee, Adapter (Conductive & Insulating)	1/2" - 2"	150 psig
Steel x Steel		Style 90 Service Tee	Tap-N-Valve Tee for IPS Services (Seal Only)	3/4" - 1"	150 psig









Service Saddles Provides Seal Only

PIPE	PRODUCT	STYLE NO.	CONFIGURATIONS	SIZES	PSI RATING
Steel or Cast		Style 91 Saddle	Service Saddle w/ Double Straps (Conductive or Insulating)	2" - 12"	150 psig

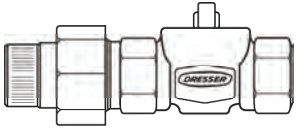

Pipe Joining - Bolted Couplings Provides Seal Only

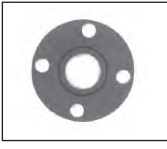
PIPE	PRODUCT	STYLE NO.	CONFIGURATIONS	SIZES	PSI RATING
Steel to Steel Cast to Cast		Style 38	Coupling	1/2" - 24" (and larger)	Varies by size and application
Steel to Steel		Style 39	Insulating Coupling	3/4" - 24" (and larger)	Varies by size and application
Steel to Steel		Style 39-40	Insulating Long Body Coupling	1" - 16"	Varies by size and application
Steel to Steel		Style 40	Long Body Coupling	1/2" - 24" (and larger)	Varies by size and application
Steel to Cast Iron		Style 39-62	Insulating Reducing Coupling	2" - 24" (and larger)	150 psig
Steel Cast Iron		Style 31	Line Cap	2" - 24" (and larger)	150 psig
Steel		Style 128	Flange Adapter	2" - 24" (and larger)	150 psig
Steel to Steel		Style 63	Expansion Joint Flanged or Weld Ends	Made To Order	150 psig

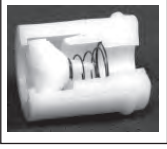

Valves & Strainers

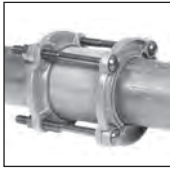
PIPE	PRODUCT	STYLE NO.	CONFIGURATIONS	SIZES	PSI RATING
IPS Steel or P.E.		Style 175 x Universal 90	Compression Meter Curb Valve (Seal & Restraint Product)	1-1/4" - 2"	150 psig
IPS Steel or P.E.		Style 175 x Universal 90	"Cut-In" Curb Valve (Seal & Restraint Product)	1-1/4" - 2"	150 psig
Steel X Steel		Style 175 GTO	Threaded Meter Curb Valve (Seal Only Product)	3/4" - 2"	175 psig
Steel	 	Style 275 275 w/ Union End	Threaded Meter Valve FIPS w/Lock Wing Available with Insulated Union on One End	3/4"- 1-1/4"	175 psig
Steel		Style 350 "Ultraseal"	Meter Valve w/Lock Plate Flange Ends Weld Ends	2"	175 psig
Pipeline Basket Strainer		Style 351 Pipeline Strainer	Tee Strainer for meters and regulation equipment 100 Mesh	Flanged: 2" ANSI 125 Weld: 2"	Flanged 175 psig; Weld 275 psig
Gasket Strainers		Style 351 Gasket	Gasket Strainer for pipeline measurement equipment (20 Mesh)	2"	175 psig
Cast/DI x P.E.		Style 575 Angle Valve	Compression End Tee	1-1/4", 1-1/2"	125 psig
Steel & P.E. Applications		Style 480 & 488 EFV's	Excess Flow Valves- Available in a variety of mechanical and fusion carrier fittings	1/2", 3/4", 1" CTS and IPS; 1/2" CTS Ultra-Low	10-125 PSI

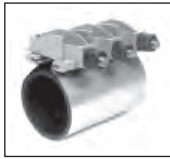



Repair Clamps

PIPE	PRODUCT	STYLE NO.	CONFIGURATIONS	SIZES	PSI RATING
Steel		Style 4/41	Collar Leak Clamp	2" - 12"	1000 psig
Steel		Style 118 "Handiband"	Band Clamp	1/2" - 3" 4" - 8"	150 psig 100 psig
Cast/ Ductile Iron		Styles 60 & 160	Bell-Joint Clamp	3" - 48"	100 psig
Steel, Cast/ Ductile Iron		Style 360	Full Circle Clamp	2" - 24"	Varies by size and application

Repair and Reinforcing Sleeves

PIPE	PRODUCT	STYLE NO.	CONFIGURATIONS	SIZES	PSI RATING
Cast/ Ductile Iron		Style 80 Sleeve	'Ready-Pack' Sleeve Repair of Cast/Ductile Iron Pipe	3" - 8"	150
Cast/ Ductile Iron		Style 126 Sleeve	'Bell-Pack' Sleeve Repair of Cast Iron Bell & Spigot Joints	3" - 24"	100
Steel		Style 54 Style 73	Split Sleeves for Repair of Steel Pipe (Low Profile)	2", 3", 4" 2"	500 500

Repair and Reinforcing Sleeves (Cont'd)

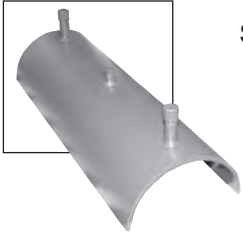
PIPE	PRODUCT	STYLE NO.	CONFIGURATIONS	SIZES	PSI RATING
Cast/ Ductile Iron		Style 50	Split Sleeve for Repair or Hot Tap of Cast/Ductile Iron	4" - 30" (and larger)	100 psig
Cast/ Ductile Iron		Style 50A Blackhawk	Hot Tap Sleeve w/Branch Outlet Options	4" - 30" and larger (Outlet by order)	100 psig
Steel		Style 96	Expanded Body Split Repair Sleeve for High Pressure Steel Pipe	6" - 24" (and larger)	500 psig
Steel		Style 110	Reinforcing Sleeve for Welded Joints (Seal & Restraint Product)	4" - 24" (and larger)	Varies by size and application
Steel		Style 220 & Low Profile 220	Reinforcing "Pumpkin" Sleeve for Coupled or Flanged Joints (Seal & Restraint Product)	2" - 42"	Varies by size and application
Steel		Style 220S Small Diameter Sleeve	Reinforcing Sleeve for Threaded Collars, Welded Joints or Compression Couplings	3/4" - 2"	350 psig
Steel		Style 115	Full-wrap Reinforcing Sleeves; Pressure-balanced Repair Sleeves	Sized on Application	Varies by size and application

Restraint Harness

PIPE	PRODUCT	STYLE NO.	CONFIGURATIONS	SIZES	PSI RATING
Steel to Steel		Style 440	Weldable Lug Joint Harness for anchoring Steel to Steel pipe	2" - 38"	Restraint Only

Blackhawk Pressure Control Fittings

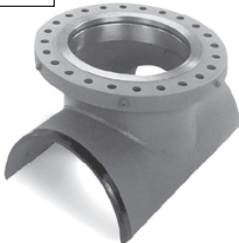
PIPE	PRODUCT	STYLE NO.	CONFIGURATIONS	SIZES	PSI RATING
Steel	 	BLACKHAWK	LS2 Fittings (Class 150 & 300) Line Stop Fittings, Hot Tap Split Sleeves, Spherical Sleeves, (Class 150, 300 & 600)	1-1/4" - 3" Threaded 4" - 12" Flanged 4" - 24"	285-740 PSI 285 TO 1480 PSI

Change-Out Kits, Prefabricated Meter Sets

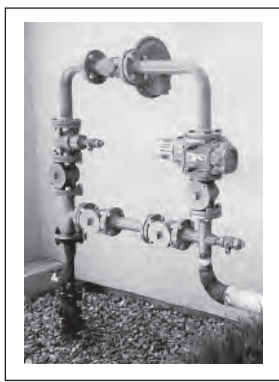
PRODUCT	STYLE NO.	CONFIGURATIONS	SIZES	PSI RATING
	Style 965	Meter Change-out Kits	Consult Factory per Application	Varies by Individual System Requirements
	Style 966	Prefabricated Meter Sets		

APPLICABLE PRODUCT WARNINGS

PIPE PULLOUT

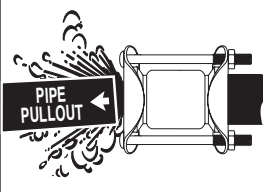

WARNING

When pipe pullout could occur, pipe joint **MUST** be anchored. Failure to anchor pipe joint could result in escaping line content and cause property damage, serious injury or death.

Styles 38, 39, 39-62, 39-40, 40, 50, 54, 63, 73, 75, 80, 88, 90, 96, 126, 128, 175, 275, 350, 360, & 575.

INSERT STIFFENER

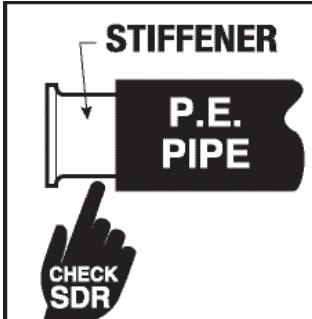

NOTE: On all polyethylene pipe ends, the recommended Dresser insert stiffener, or an insert stiffener the user has qualified to meet CFR Title 49, DOT 192.283(b), must be installed.

Styles 88, 90, 401, 501, 575, 700 & 711.

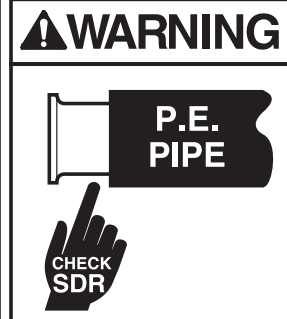

WARNING

Use proper insert in P.E. pipe end. Improper insert could result in escaping line content that could cause property damage, serious injury or death.

MARK & STAB

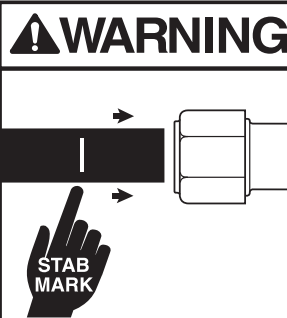

WARNING

You **MUST** mark and stab the pipe into the fitting to the proper stab depth. Failure to do so could result in escaping line content that could cause property damage, serious injury or death.

Styles 38, 40, 50, 54, 65, 80, 88, 90, 96, 126, 128, 175, 275, 350, 360, 401, 501, 575, 700 & 711.

Style 480 & 488 EXCESS FLOW

WARNINGS

Proper selection of Excess Flow Valves is required. Improper selection can result in a condition that will not allow the device to operate, creating the potential for a dangerous condition if the line is severed.

Be certain of the proper orientation of the excess flow valve when installed in the service line. EFV devices installed backwards will not operate.

ALWAYS READ ALL OF THE INSTALLATION / OPERATION INSTRUCTIONS, CAUTIONS AND WARNINGS WHEN SELECTING OR INSTALLING EXCESS FLOW VALVES! FAILURE TO FOLLOW THE ABOVE WARNINGS COULD RESULT IN IMPROPER OPERATION AND ESCAPING GAS THAT MAY CAUSE PROPERTY DAMAGE, SERIOUS INJURY OR DEATH!

NOTE:
**ALWAYS READ THE DRESSER
 INSTALLATION INSTRUCTIONS
 AND WARNINGS
 BEFORE INSTALLING ANY
 DRESSER PRODUCT!**

SPECIAL PRODUCT WARNINGS

Style 501 TAP-N-VALVE Tees and 501 WELD ADAPTERS

⚠ WARNING

On Weld Adapters, remove all compression end components before welding. Failure to do so could destroy the gasket and result in escaping gas that could ignite and cause property damage, serious injury or death.

⚠ WARNING

On Weld Inlet Tees, remove tapping tool and all compression end components before welding. Failure to do so could damage the tapping tool and destroy the gasket, resulting in escaping gas that could ignite and cause property damage, serious injury or death.

Style 700 UNIVERSAL POSI-HOLD®

⚠ WARNING

For Universal POSI-HOLD® Couplings Only:

When P.E. pipe is used, the proper SDR Dresser insert **MUST** be used in each P. E. pipe end. Improper insert could result in escaping line content that could ignite and cause property damage, serious injury or death.

⚠ WARNING

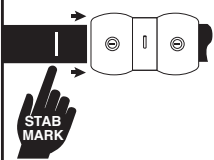

You **MUST** mark and stab the pipe into the coupling to the proper stab depth. Failure to do so could result in escaping gas that could ignite and cause property damage, serious injury or death.

⚠ WARNING

When pipe movement out of the coupling might occur as a result of forces other than that caused by internal line pressure of 150 PSI Max., proper anchorage **MUST** be provided!

Style 31 LINE CAPS

⚠ WARNING



Style 31 Line Caps **MUST NOT** be used under pressure without anchorage or blocking sufficient to withstand the entire longitudinal thrust due to internal pressure. Failure to do so could allow line cap to blow off the line, causing serious injury or death. Also, escaping line content could cause property damage, serious injury or death.

⚠ WARNING

Do **NOT** remove tapping tools while line cap is under pressure. To do so could allow the line cap to blow off and result in serious injury or death. Also, escaping line content could ignite and cause property damage, serious injury or death.

NOTE:

**ALWAYS READ THE DRESSER
INSTALLATION INSTRUCTIONS
AND WARNINGS
BEFORE INSTALLING ANY
DRESSER PRODUCT!**

Dresser™ Pipeline Solutions

41 Fisher Avenue
Bradford, PA 16701
T: 814.362.9200
F: 814.362.9344

© 2018 Natural Gas Solutions North America, LLC – All rights reserved. Natural Gas Solutions reserves the right to make changes in specifications and features shown herein, or discontinue the product described at any time without notice or obligation. Contact your Dresser Natural Gas Solutions representative for the most current information.

The Dresser Logo and all Trademarks containing the term “Dresser” are the property of Dresser, LLC, a subsidiary of Baker Hughes, a GE Company.



www.dresserngs.com

NGS-DPS-015
GAS.PRODUCT.GUIDE.10.18